

MDC-8220TDN

DOME CAMERA



GENERAL FEATURUES

- 1/3" SONY Super HAD Color CCD (410K Pixels)
- More than 580 TV Lines (color), 700 TV Lines (B/W)
- Disk saving with DNR Technology
- Low Sensitivity of 0.001 Lux (Sens-up)
- Built in 2.8~11mm Filter changeable Varifocal DC Auto Iris Lens
- Multi OSD function built-in
 - Privacy, Motion Detection, HLC etc.
- Vandal Resistant Dome Housing, 3 Axis
- Weatherproof Housing (IP66)
- DC12V Power Source



DIMENSIONS(mm)

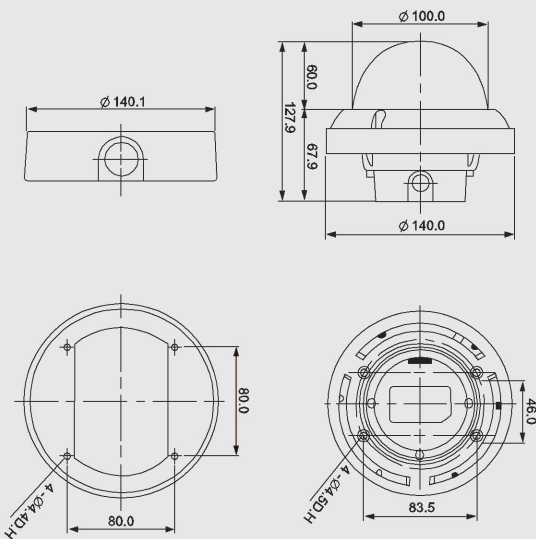

SPECIFICATIONS

MODEL	MDC-8220TDN	
ITEM	NTSC	PAL
Image Sensor	1/3" Sony Super HAD Color CCD	
Effective Pixel	768(H) x 494(V) 380K	752(H) x 582(V) 440K
Scanning System	525 Lines 2:1 Interlace	625 Lines 2:1 Interlace
Scanning Frequency	15.734KHz (H), 59.94Hz (V)	15.625KHz (H), 50Hz (V)
Resolution	More than 580TV Lines (Color), 700TV Lines (B/W)	
Shutter Speed	1/60 ~ 1/100,000 sec	1/50 ~ 1/100,000 sec
S/N Ratio	More than 52dB (AGC off)	
Sync System	Internal	
Lens	2.8~11mm ICR Varifocal DC Auto Iris Lens	
Min. Illumination	0.15 Lux(Color) / 0.03 Lux(B/W) / 0.001(Sens-up) at F 1.2	
White Balance	ATW / AWC / MANUAL / OUTDOOR / INDOOR	
Video Output	Composite 1.0Vp-p(75Ω load)	
Power Supply	DC12V ±10%	
Operating Temp.	-10°C ~ +50°C	
Operating Humidity	90% RH max.	
Dimension (m/m)	100mm Dome size & Approx. 1200g	