

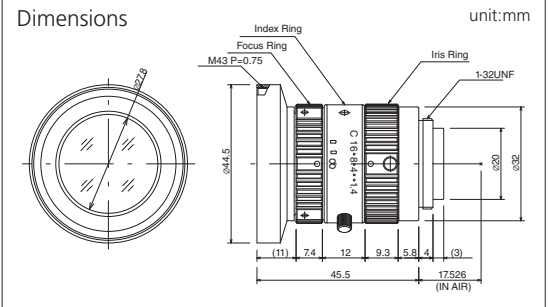

- FIX
- MANUAL
- MEGA PIXEL
- FA



MODEL NO.	H0514-MP2
Format (")	1/2
Mount	C
Focal Length (mm)	5
Aperture (F)	1.4-16C
Angle of View (HOR)°	65.5
M.O.D. (m)	0.3
Effective Aperture	Front (φmm) 27.8
	Rear (φmm) 14.8
Front Filter Thread (φMxP=)	43.0 × 0.75
Dimensions	$\phi 44.5 \times 45.5$
Weight (g)	102



- FIX
- MANUAL
- MEGA PIXEL
- FA



NEW

MODEL NO.	M3514-MP
Format (")	2/3
Mount	C
Focal Length (mm)	35
Aperture (F)	1.4-16C
Angle of View (HOR)°	13.9
M.O.D. (m)	0.3
Effective Aperture	Front (φmm) 24.0
	Rear (φmm) 12.0
Front Filter Thread (φMxP=)	-
Dimensions	$\phi 33.0 \times 38.2$
Weight (g)	87

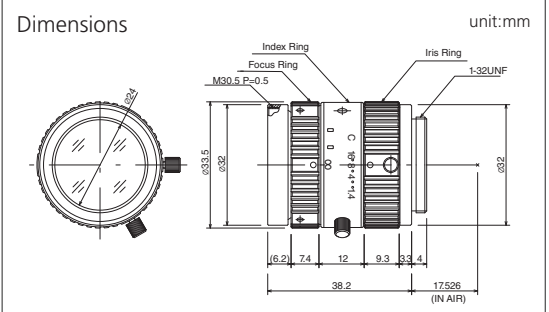

- FIX
- MANUAL
- MEGA PIXEL
- FA



NEW

MODEL NO.	M7528-MP
Format (")	2/3
Mount	C
Focal Length (mm)	75
Aperture (F)	2.8-16C
Angle of View (HOR)°	6.8
M.O.D. (m)	0.3
Effective Aperture	Front (φmm) 24.8
	Rear (φmm) 13.6
Front Filter Thread (φMxP=)	-
Dimensions	$\phi 35.0 \times 57.75$
Weight (g)	113

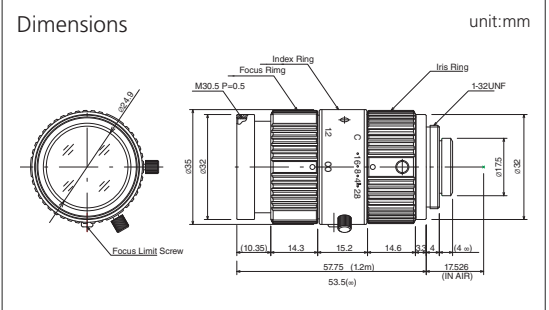

- ZOOM
- MANUAL
- MEGA PIXEL
- FA



MODEL NO.	MLM-3XMP
Format (")	2/3
Mount	C
Focal Length (mm)	* 0.3-1.0X
Aperture (F)	4.5-22C
Angle of View (HOR)°	11.8-2.78
M.O.D. (m)	0.09
Effective Aperture	Front (φmm) 15.5
	Rear (φmm) 7.0
Front Filter Thread (φMxP=)	34.0 × 0.5
Dimensions	$\phi 36.5 \times 79.5$
Weight (g)	150

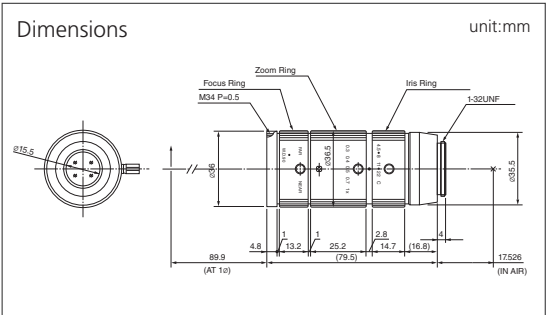

NOTES : Macro Zoom Lens * mark shows Maximum Magnification

FEATURE INDICATION
 MODEL NAME
 CODING RULE
 MANUAL IRIS
 AUTO IRIS
 VARI-FOCAL
 MANUAL IRIS
 VARI-FOCAL
 AUTO IRIS
 MANUAL ZOOM
 MOTORIZED ZOOM
 PINHOLE
 ACCESSORIES
 MEGAPIXEL & FA
 TECHNICAL INFORMATION
 ANGLE OF VIEW