

Digital Access Keypad DK-10 User/Installer Manual

PIMA

FOR BETTER PROTECTION



P/N 4410057 Rev. B (Dec-2003)



PIMA Electronic Systems Ltd.

5 Hatzoref Street, Holon 58856, Israel

+972-3-5587722

+972-3-5500442

✉ support@pima-alarms.com

🌐 <http://www.pima-alarms.com>

PIMA Electronic Systems Ltd. does not represent that its Product may not be compromised and/or circumvented, or that the Product will prevent any death, personal and/or bodily injury and/or damage to property resulting from burglary, robbery, fire or otherwise, or that the Product will in all cases provide adequate warning or protection. The User understands that a properly installed and maintained equipment may only reduce the risk of events such as burglary, robbery, and fire without warning, but it is not insurance or a guarantee that such will not occur or that there will be no death, personal damage and/or damage to property as a result.

PIMA Electronic Systems Ltd. shall have no liability for any death, personal and/or bodily injury and/or damage to property or other loss whether direct, indirect, incidental, consequential or otherwise, based on a claim that the Product failed to function.

Warning: The user should follow the installation and operation instructions and among other things test the Product and the whole system at least once a week. For various reasons, including, but not limited to, changes in environment conditions, electric or electronic disruptions and tampering, the Product may not perform as expected. The user is advised to take all necessary precautions for his/her safety and the protection of his/her property.

This document may not be duplicated, circulated, altered, modified, translated, reduced to any form or otherwise changed, unless PIMA's prior written consent is granted.

All efforts have been made to ensure that the content of this manual is accurate. Pima retains the right to modify this manual or any part thereof, from time to time, without serving any prior notice of such modification.

Please read this manual in its entirety before attempting to program or operate your system. Should you misunderstand any part of this manual, please contact the supplier or installer of this system.

Copyright © 2004 by PIMA Electronic Systems Ltd. All rights reserved.

You can contact us at:
PIMA Electronic Systems Ltd.
5 Hatzoref Street, Holon 58856, Israel

<http://www.pima-alarms.com>

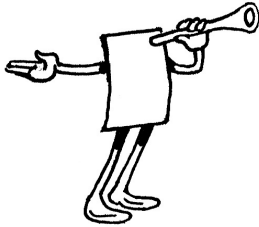
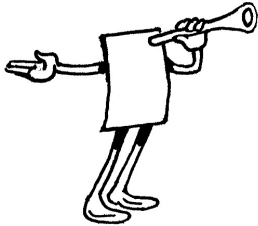

Table of Contents

Introduction	5
<i>Main Features of the DK-10</i>	5
<i>Specifications</i>	7
<i>Code Description</i>	7
Using the DK-10	7
<i>LEDs and Tones</i>	8
<i>Programming</i>	8
<i>Operating Outputs</i>	9
Installing the DK-10	11
<i>Assembling Keypad</i>	11
<i>Terminal Block</i>	12
<i>The DAP Jumper (Direct Access to Programming)</i>	14
<i>Operating the Keypad</i>	14
<i>Configuration of Relay Outputs</i>	14
<i>Reprogramming the Keypad</i>	15
<i>Initializing the Keypad</i>	15
Appendix 1:General Programming Instructions	16
Appendix 2: Typical Application	18

This page was intentionally left empty



INTRODUCTION

Congratulations on your purchase of PIMA's DK-10 Digital Access Keypad. Much care has been taken in developing this product in order to provide you the best protection possible. It is advisable to read this manual prior to using and installing the Digital Access Keypad, in order to take advantage of its full potential.

PIMA offers you a choice between three different keypad models:

- ◆ **DK-10:** Assembled from a single standalone unit that includes the access control unit. This model includes 100 User Codes, enabling up to 100 million combinations.
- ◆ **DK-30C:** Assembled from two units- an external keypad and an inner Controlling Unit
- ◆ **DK-80C:** Similar to the DK-30C model, including Doorbell and Internal Buzzer

**NOTE:**

Only two wires connect the keypad and the control unit.

Main Features of the DK-10

- ◆ Top Code Security; Up to 100 million combinations
- ◆ Up to 120 User Codes
- ◆ Water-Resistant External Unit
- ◆ 24H Tamper Switch secures the external unit
- ◆ Electronic Lock after 10 successive false codes; release after 15 min.
- ◆ Output to Silent Alarm when opening door, in case of robbery
- ◆ Non-Volatile Memory, in case of power failure
- ◆ 5 Amp Relay Output for durable activity
- ◆ Keypad Light activated for 10 sec. by key pressing

- ◆ Audible Keys & Visible LED Signals
- ◆ Two Transistor Outputs

This page was left empty intentionally



USING THE DK-10

Specifications

- ◆ Operating Voltage: AC/DC 10-14 V
- ◆ Current Consumption: 50-80 mA (without Electric Lock)
- ◆ Output #1 (Relay): Max current (5 A)
- ◆ Output #2 & #3: 2 transistor outputs up to 100 mA

Code Description

A multiple number of user codes is definable for each output. Each code consists between 4 to 8 digits. To activate the exit, press  to confirm the entered code. Following are the existing User Codes in each output:

- ◆ Group 1 User Codes for output 1: 100 user codes
- ◆ Group 2 User Codes for output 2: 10 user codes
- ◆ Group 3 User Codes for output 3: 10 user codes



NOTES:

A Duress Code is automatically generated for each entered User Code (the Code plus 2 to the first digit) In order to prevent a situation in which one user code is identical to the Duress Code, the system does not accept User Codes+2 or -2. For example, user code 56789 is saved in the system; therefore, codes 36789 and 76789 will not be accepted as new User Codes.



IMPORTANT!

For safety reasons, the primary code **must** be altered after installation. The factory's Default Master Code is 0000.

LEDs and Tones

The built-in buzzer and the a yellow LED indicator give the following tones and signals for operation status:

Function	Tones	LED Signals
Entering programming mode	2 beeps	ON
Successful code entry	2 beeps	1 flash
Unsuccessful code entry	5 beeps	5 flashes
DAP jumper not replaced	Continuous Beeps	Continuous Flashes
Standby mode	-	A flash every 2 seconds



IMPORTANT!

The factory default is Master Code 0000 and a Multiple User Code for each output. In order to use a single User Code, reprogram the system.

Programming





IMPORTANT!

The  symbol indicates entering data.

- ◆ Enter Programming Mode with the Factory Default Master Code:

 **0**  **0**  **0**  **0**  *****

- ◆ Programming New Master Code

 **0**  New 4 to 8 digit Code  **#**

- ◆ Programming User Code 1 in group 1, with Duress Code and System Disarming Code:

 **1**  **0**  **1**  New 4 to 8 digit Code  **#**

- ◆ Programming User Code 2 in group 1, with Duress Code and System Disarming Code:

1 **0** **2** New 4 to 8 digit Code **#**

- ◆ Programming User Code 99 in group 1:

1 **9** **9** New 4 to 8 digit Code **#**

- ◆ Programming User Code 1 in group 2:

2 **1** New 4 to 8 digit Code **#**

- ◆ Programming User Code 2 in group 2:

2 **2** New 4 to 8 digit Code **#**

- ◆ Programming User Code 1 in group 3:

3 **1** New 4 to 8 digit Code **#**

- ◆ Programming User Code 2 in group 3:

3 **2** New 4 to 8 digit Code **#**

- ◆ To save all data and exit programming mode:



NOTE:

In case of wrong entry during programming, cancel it with **#** key, or wait 10 seconds before re-entering it.

Operating Outputs

- ◆ Control Output 1: Enter one of Group 1 User Codes, and press **#**
- ◆ Control Output 2: Enter one of Group 2 User Codes, and press **#**
- ◆ Control Output 3: Enter one of Group 3 User Codes, and press **#**
- ◆ Master Code: Uses also as Super User Code. Allows user to operate all three outputs with a single code

In order to control outputs 1 to 3 using the Master Code:

Master Code **#** No. of the required Output

- ◆ **Duress Code:** Does not need to be programmed. The system automatically determines it by increasing the first digit of the User Code by two digits. E.g., if User Code 1 is 3247, the Duress Code is automatically set to 5247. Similarly, if the first digit is 8, such as in User Code 8321, the Duress Code will be 0321. If the first digit is 9, such as in User Code 9326, the Duress Code will be 1326
- ◆ **Short Code:** The User Code first two digits (e.g. if User Code is 3247, Short Code is 32)
- ◆ **Entering False Codes:** Enter a number of false codes in order to test this feature. The keypad generates 5 beeps for each unsuccessful code entry. The keypad locks for 15 minutes after 10 successive false codes are entered. Only the Master Code can deactivate the keypad during these 15 minutes:



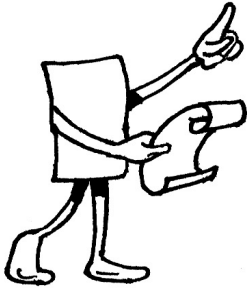

INSTALLING THE DK-10

Assembling Keypad

- ◆ Open with an “Allen” wrench (supplied with unit) the two screws at the keypad’s bottom
- ◆ Pull down the front part only, in order to separate between the two parts of the keypad
- ◆ Make sure the operating voltage does not exceed 14V (AC/DC) and current is sufficient to activate electric lock
- ◆ Make sure the water drainage holes are clear. If necessary, enlarge them up to 5 mm by drilling
- ◆ The Cable output must be properly sealed (e.g. Silicon)

Terminal Block

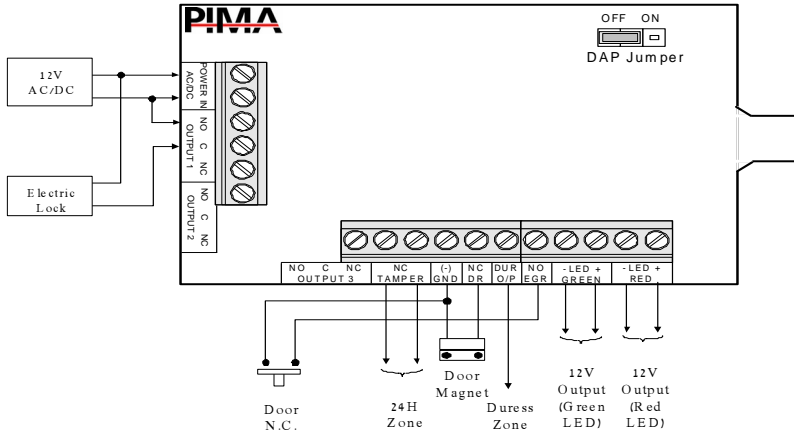

- ◆ **POWER in AC/DC:** 12V AC or DC
- ◆ **OUTPUT 1:** 5 Amp dry relay contacts, with Normally Open (N.O.) and Normally Close (N.C.) terminals. This relay is primarily prepared for door strike application, or for alarm ON-OFF control. Relay is programmable in two modes:

Toggle mode: ON/OFF relay with code or short code

Temporary mode: Activate relay with code; the relay automatically switches back after programmed time



NOTE:

If DC voltage is used, no buzz will be extracted when opening lock.

- ◆ **OUTPUT 2:** Output 2 is prepared for ON-OFF control or for reporting panic event to an alarm system or to a telephone dialer. The output is programmable for momentary or start/stop operation
NPN transistor open collector output, switch of the (-) supply
- ◆ **OUTPUT 3:** Identical function as output 2. Recommended for alarm ON-OFF control or for auxiliary functional control in your system
- ◆ **TAMPER N.C.:** Tamper switch Normally Close contact; Triggered when the keypad is opened
- ◆ **GND (-):** The (-) grounding point of the keypad panel
- ◆ **NC DR:** This terminal is prepared for connecting a Normally Closed optional door sensing switch to a door which is controlled by output 1, for initiating the auto re-lock function
In normal operation without the door-sensing switch, an opened door is re-locked after timeout in momentary mode, or by entering Code 1 again in Start/Stop mode
- ◆ **DUR O/P:** NPN transistor open collector output, switches the (-) when the Duress Code is entered. Use this output to trigger remote alarm, dialer, indicator etc., in case of duress
- ◆ **EGR N.O.:** A Normally Open (N.O.) input refers to (-) ground with the help of a normally open button to activate the Relay Output 1. Egress button is usually put inside the house near the door. Leave this terminal open if not used
- ◆ **Green and Red LEDs:** Two built-in LED lamps, indicating alarm or door opening status

The DAP Jumper (Direct Access to Programming)

If the Master Code is lost, use the DAP jumper to override the code permitting direct entry into programming mode:

1. Disconnect power supply
2. Displace the DAP jumper from OFF to ON position
3. Reconnect power supply (buzzer activated), and wait 10 sec.
4. Put the DAP jumper back to OFF position (stops the buzzer)
5. The keypad is now in **programming mode** and ready to receive new data
6. Master Code returns to be the Factory Default Code (0000)

Operating the Keypad

Configuration of Relay Outputs

- ◆ Configuration of Outputs to Momentary mode (time limited):

Output 1: **4** **0** No. of seconds (1-999) **#**

Output 2: **5** **0** No. of seconds (1-999) **#**

Output 3: **6** **0** No. of seconds (1-999) **#**

- ◆ Configuration of Outputs to SRART/STOP mode with regular codes only:

Output 1: **4** **1** **#**

Output 2: **5** **1** **#**

Output 3: **6** **1** **#**

- ◆ Configuration of Outputs to SRART/STOP mode with the regular or Short Codes:

Output 1: **4** **2** **#**

Output 2: **5** **2** **#**

Output 3: **6** **2** **#**

Reprogramming the Keypad

It is possible to change data at all times, such as User Code, Door-Sensing Switch etc.

1. Enter Programming Mode:



2. Enter desired access key and updated data:

See table “General Programming Instructions” on page 13

3. To save all data and exit programming mode:



Initializing the Keypad

1. Enter Programming Mode:



2. Resetting System:



3. Enter New Data:

See table: “General Programming Instructions” on page 13

4. Exit Programming Mode and Save Data:



APPENDIX 1: GENERAL PROGRAMMING INSTRUCTIONS

Feature	Access Code	Possible Values Single /Multiple Users	Description
Master Code	0	4 digits/4-8 digits	For programming only
User Code 1	1	4 digits/4-8 digits	
User Code 2	2	4 digits/4-8 digits	
User Code 3	3	4 digits/4-8 digits	
Duress Code	----	----	Automatically programmed by adding "2" to the User Code first digit
Temporary Output 1	40	1 to 999 sec.	Sec. to activate Relay Output
Permanent Output 1	41	----	ON/OFF relay with User Code
Permanent Output 1	42	----	ON/OFF relay with User Code/ Short Code
Temporary Output 2	50	1 to 999 sec.	Sec. to activate Output
Permanent Output 2	51	----	ON/OFF relay with User Code
Permanent Output 2	52	----	ON/OFF relay with User Code/ Short Code
Temporary Output 3	60	1 to 999 sec.	Sec. to activate Output
Permanent Output 3	61	----	ON/OFF relay with User Code
Permanent Output 3	62	----	ON/OFF relay with User Code/ Short Code
False Code	70	----	Locked for 30 sec. after 10 false codes
False Code	71	----	Activate Alarm System Duress Output after 10 false codes
False Code	72	5 to 10	Locked for 15 min. after 5/10 false codes. Reset with Master Code

False Code	76	0-0	Cancel features 70 & 71
------------	----	-----	-------------------------

APPENDIX 2: TYPICAL APPLICATION

Output 1: Door Strike

Output 2: Main Alarm Control

Output 3: Auxiliary Alarm Control

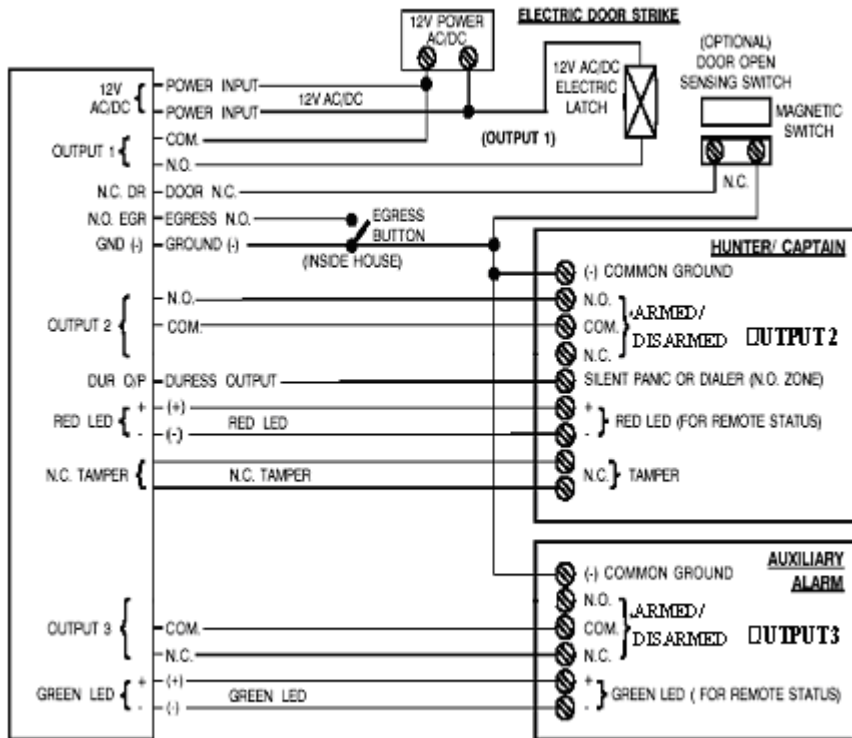

- ◆ For control panels that use N.O. as key input, use output 2
- ◆ For control panels that use N.C. as key input, use output 3

